

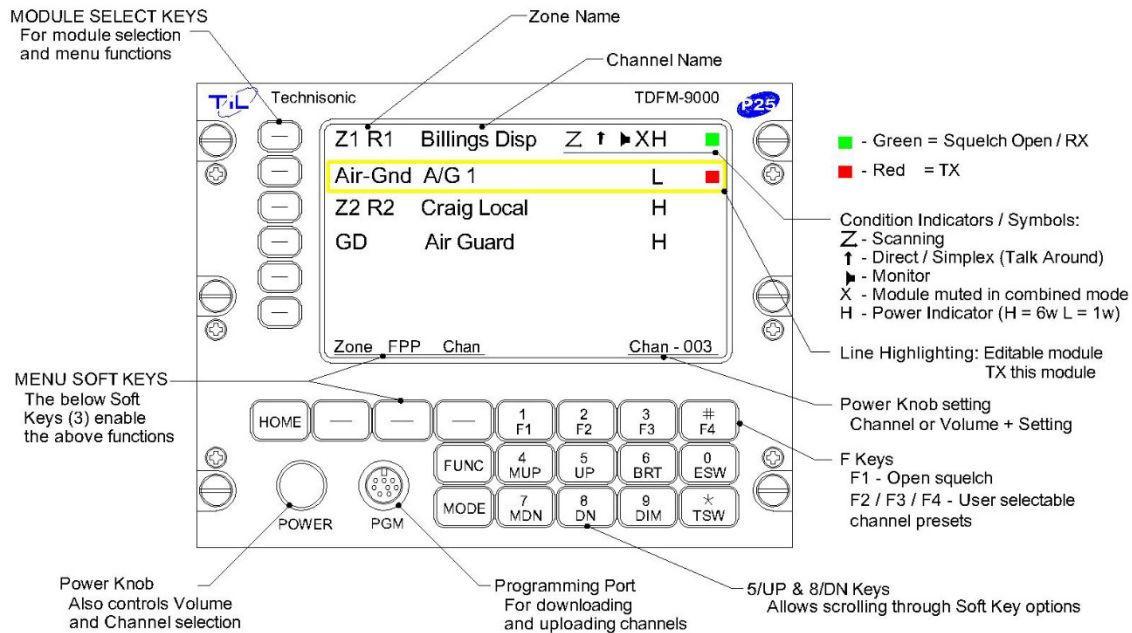

NIICD TDFM-9000 Quick Reference Guide



October 13, 2017



TDFM-9000 series radio buttons have multiple configuration options depending on how they are setup during initial programming using Motorola's CPS software. The NIICD TDFM-9000 Quick Reference Guide only applies to TDFM-9000 radios configured using a NIICD codeplug.

Turn Radio On or Off

1. Press & hold the **POWER** knob.

Select A Radio for Transmission

1. Press the Module Select Softkey to place a box around the desired module.

Adjust Radio Volume

Note: Each radio's volume is individually set.

1. Press the Module Select Softkey to place a box around the desired module.
2. Press (1/F1) key (opens radio's squelch) or press & hold (1/F1) key for 2 seconds to have squelch remain open (a short beep is heard).
3. Briefly press the **POWER** knob until "Vol-xx" is displayed in the lower right corner of the display.
4. Rotate the **POWER** knob for desired level.
5. If radio squelch is still open press (1/F1) key again to close it.







Muting a Radio

Note: Each radio's volume can be individually muted when the radio is set to combined mode.



1. Press the Module Select Softkey to place a box around the desired module.
2. Press the Module Select Softkey a second time to mute that band. An "X" appears on that module.

Change Zones

Note: Users cannot create zones.





1. Press Module Select  Softkey to place a box around the desired module.
2. Press **Zone**  Menu Softkey.
3. Rotate **POWER** knob,  (5/UP) or  (8/DN) keys to move cursor to desired Zone.
4. Press the **Sel**  Menu Softkey to accept change
5. Press the **Exit**  Menu Softkey to abandon changing Zones

Change Channels

1. Press the Module Select  Softkey to place a box around the desired module.
Then
2. Briefly press the **POWER** knob until “Chan-xxx” appears in the lower right corner of the display.
3. Turn the **POWER** knob until the desired channel is shown.
Or
2. Press the  (5/UP) or  (8/DN) keys.











View Programmed Channel Information

Note: Any information edited while in the viewing mode will not be saved.





1. Press Module Select  Softkey to place a box around the desired module.
2. Change to desired channel (see above for changing channels).
3. Press **FPP**  Menu Softkey.
4. Press Module Select  Softkey to place a box around the desired information.
5. Press Module Select  Softkey again to toggle between RX and TX settings.
6. Press  (HOME) to return to main screen.

Load a New Channel

Only Zone “FPP Anlg” permits loading analog channels and Zone “FPP P25” permits loading P25 digital channels. There are 20 channels available to program in each FPP zone.

1. Press Module Select  Softkey to place a box around the desired module.
2. Press **Zone**  Menu Softkey.
3. Rotate **POWER** knob,  (5/UP) or  (8/DN) keys to move Zone cursor to “FPP xxx”.
4. Press the **Sel**  Menu Softkey to accept change
5. Briefly press the **POWER** knob until “Chan-xxx” appears in the lower right corner of the display.
6. Turn the **POWER** knob until the desired channel is shown.
7. Press **FPP**  Menu Softkey.
8. Press Module Select  Softkey to place a box around the information to be changed.
9. Press Module Select  Softkey again to toggle between RX and TX settings.
10. *Slowly* enter desired changes then press the **OK**  Menu Softkey to save the change.
 - a. **Freq** Direct frequency editing
 - b. **TPL** CTCSS Tones. Rotate **POWER** knob to select desired tone then press the **OK**  Menu Softkey.
 - c. **DPL** Digital analog tones. Seldom used. Rotate **POWER** knob to select desired tone then press the **OK**  Menu Softkey.





d. **NAC** P25 Network Access Code. Only editable on “FPP P25” Zone. Press Module Select  Softkey to toggle between *Rx NAC*, *Tx NAC* and *Tlkgp ID*.

- Press **123**  Menu Softkey to enter numbers.
- Press **ABC**  Menu Softkey to enter letters.
A = 1, B = 2, C = 3, D = 4, E = 5, F = 6
- Press **Corr**  Menu Softkey to backup cursor.
- Press **OK**  Menu Softkey to accept changes.

e. **RX Mode** Preset

f. **Zone Name** Press the Module Select  Softkey to toggle between *Zone Name* and *Chan Name*.

Do not change Zone name.

1. Press Module Select  Softkey until “*Chan Name*” is displayed.
2. Rotate **POWER** knob to change the flashing character. All available characters appear one after the other: Capitals, lower case, numbers & special characters then it repeats.
3. Press **Corr**  Menu Softkey to backup cursor.
4. Press **Next**  Menu Softkey to move to the next character.
5. Press **OK**  Menu Softkey to save information.

11. Press  (HOME) to return to main screen.